

# towing information

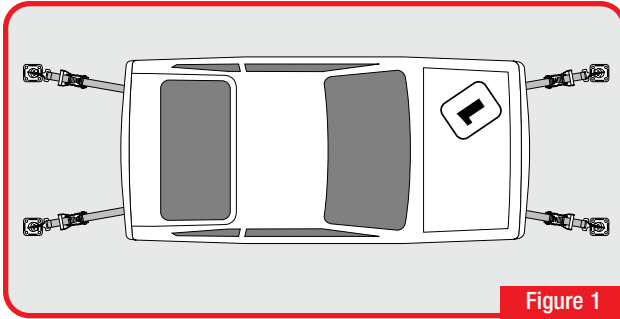

Figure 1

## Securing Car to Trailer

- 1 Always use (2) front and (2) rear tie-downs as shown in Figure 1.
- 2 Make sure the tie-down points on the vehicle and trailer are adequate to secure your vehicle. Higher tie-down ratings are always better than not enough.
- 3 Shock absorber manufacturers recommend tying the car down securely using a frame mounting point or tow hook to prevent shock wear or damage. If you must tie the car down using the axles or suspension, make sure you use sleeved axle straps or sleeved ratchet tie-downs. These are designed to prevent abrasion to the straps. Do not overtighten the straps or there is a chance the shocks will bottom and get damaged.

## Calculating Tie-Down Needs

- 1 During normal transportation of your vehicle it does not encounter big loads, but in the event of collision, the load can increase dramatically. If you have a 5G collision with a 2000 lb. vehicle, you are loading two of the tie-downs with a 10,000 lb. load. A 10G collision would see a load of 20,000 lbs.
- 2 So as a general rule, more strength is better. Use this formula to help determine what you need in the way of tie-downs.

G-Force of Collision	x	Weight of Vehicle	=	Breaking Strength
----------------------	---	-------------------	---	-------------------

### Example

10G	x	2000 lbs.	=	20,000 lbs.
-----	---	-----------	---	-------------

- 3 Tie-downs should be tightened equally as possible. Tie-downs cannot keep vehicle secured in every collision - again, more is better.

## About Tie-Down Ratings

- 1 The D.O.T. Requires a working load rating. This rating is calculated to be 1/3 of the breaking strength. For example; a 10,000 lb. breaking strength tie-down has a D.O.T. working load of 3,333 lbs. Make sure when you buy tie-downs a D.O.T. working load or breaking strength is shown.

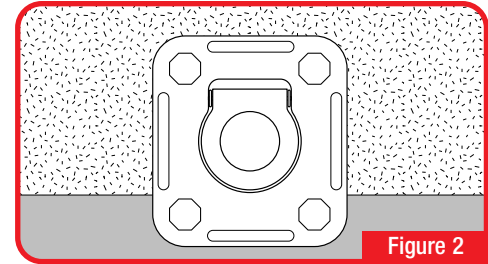

Figure 2

- 1 Recessed D-Rings should be mounted to the base of a trailer with Grade 8 hardware. Figure 2.

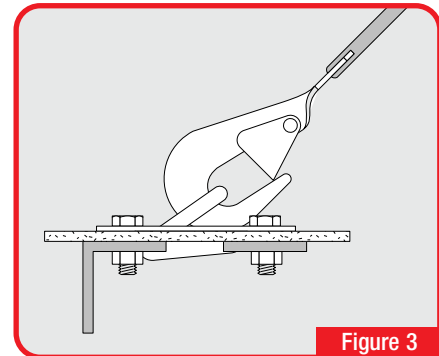

Figure 3

- 2 Rear of D-Ring bolt holes should be attached through frame of trailer at a minimum. Front mounting points should be reinforced if at all possible. NEVER mount D-Rings only to the wood, aluminum floor or to the frame of the trailer. Figure 3.

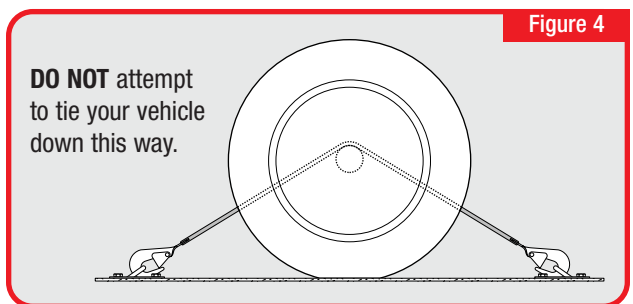

Figure 4

## Important Tie-Down Info

- 1 NEVER tie your vehicle down with the tie-down strap across the top of an axle. Vehicle will move back and forth either breaking the tie-down or will pull the tie-down mounting point from the trailer. Figure 4.
- 2 NEVER use nylon webbed tie-downs typically available at hardware stores. They will stretch as your vehicle is towed down the road. Vehicle can come loose causing the tie-down to fail. Use high quality, high strength polyester stretch resistant webbing.
- 3 **WARNING:** Inspect tie-downs before each use for abrasion, wear and cuts. A 1/4" cut in a 2" wide tie-down can reduce its strength by up to 50%. If a strap is abraded or cut, buy a replacement.